

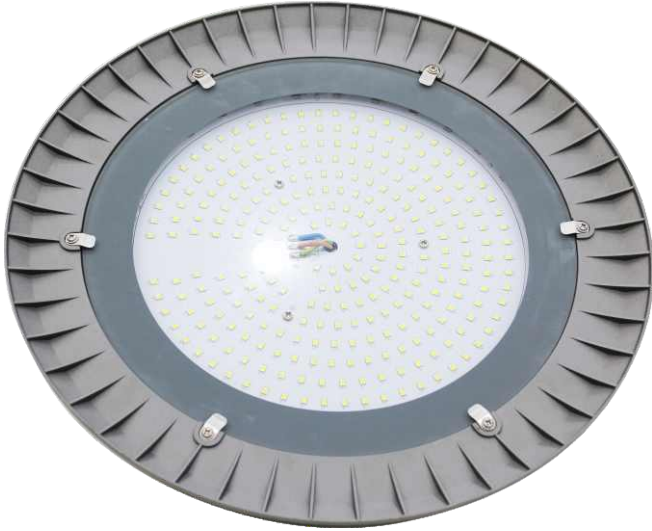

# LED high bay lamp-HG series specifications



- ◆High luminous efficacy 100lm/w
- ◆Input voltage: 200-240VAC
- ◆2 years warranty

Shenzhen YYC-LED lighting Co.,Ltd

Tel: +86-755-81702355

Fax: +86-755-81702285

Website: [www.yyc-led.com](http://www.yyc-led.com)

Address L No.6, Tongfuyu Industrial Zone, Kukeng, Guanlan Street,  
Longhua District, Shenzhen City, Guangdong Province, China.



## Product Specifications

Model#	HG063	HG103	HG153	HG203
Power	60W	100W	150W	200W
Input voltage	200~240VAC 50Hz			
Power Factor	PF≥0.9			
CCT	3000K、4000K、5000K、6000K、			
Lumen efficiency	100lm/w			
CRI	Ra≥70			
Beam angle	110°			
IP rate	IP65			

## Product Dimensions

	D	H	H1
HG063	∅304.9	55	79
HG103	∅304.9	55	79
HG153	∅354.9	65	89
HG203	∅354.9	65	89

unit : mm

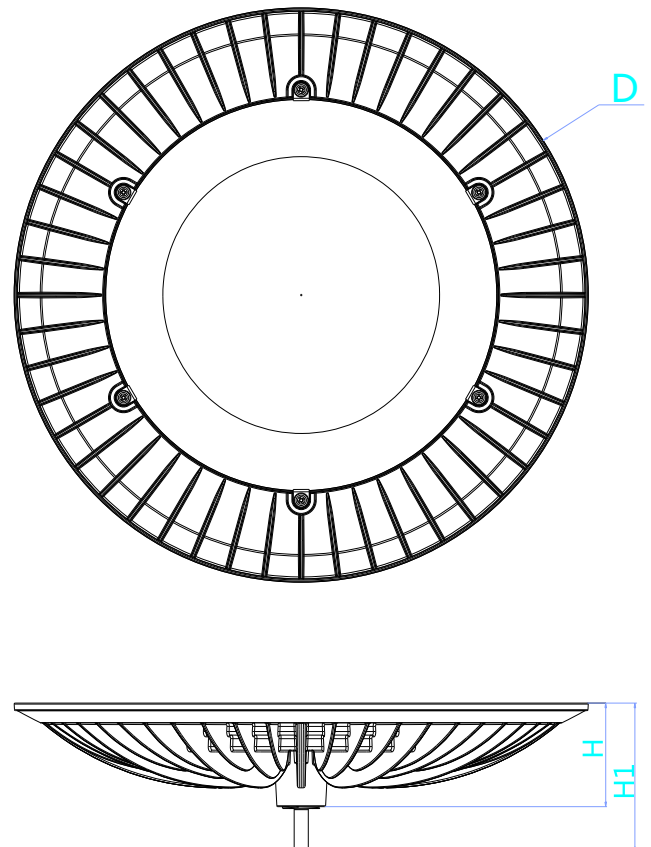

200W

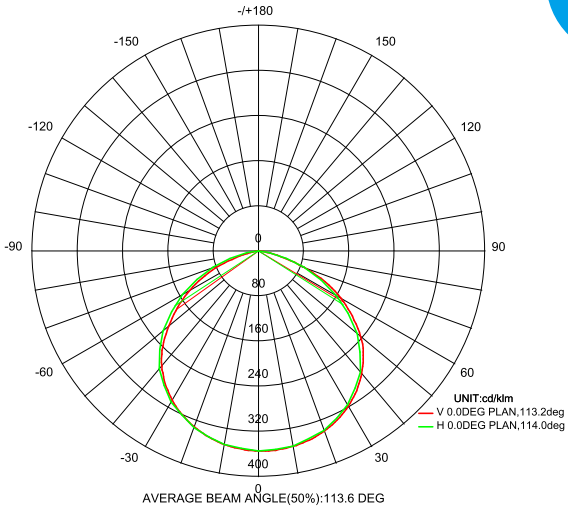

Flux out:13878 lm

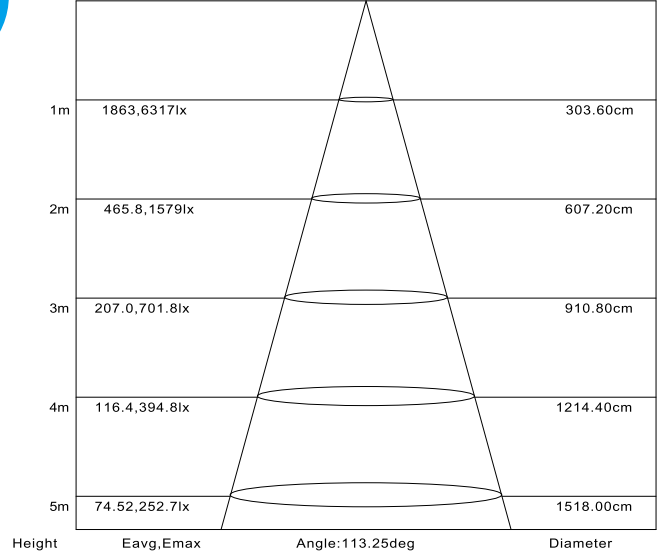

150W

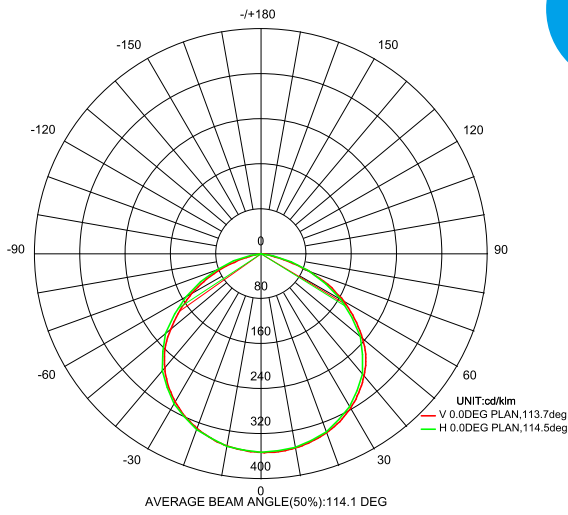

Flux out:10032 lm

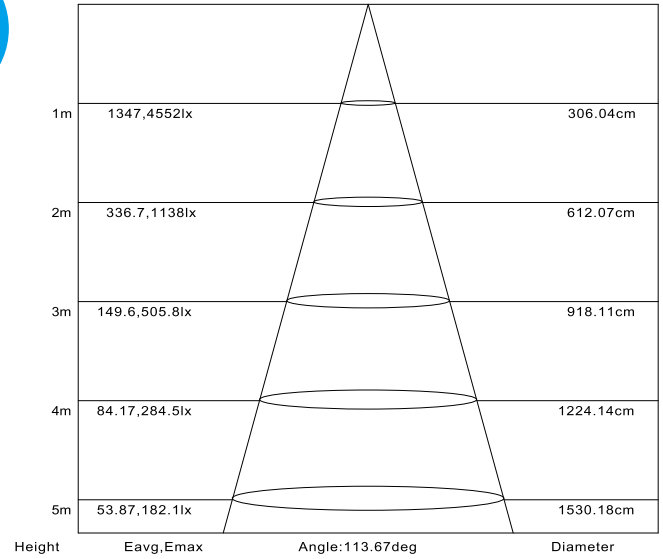

100W

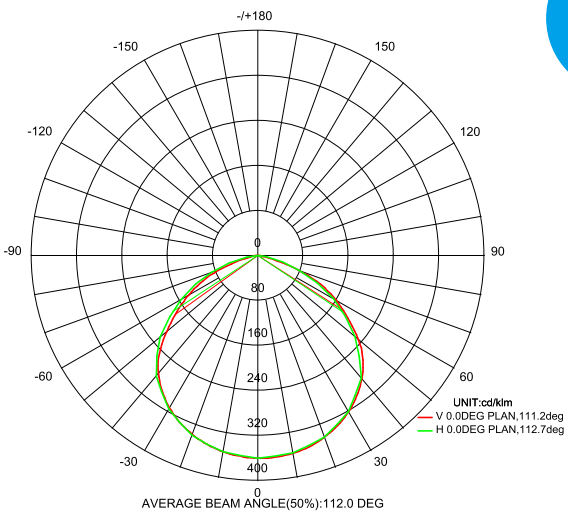

Flux out:6859 lm

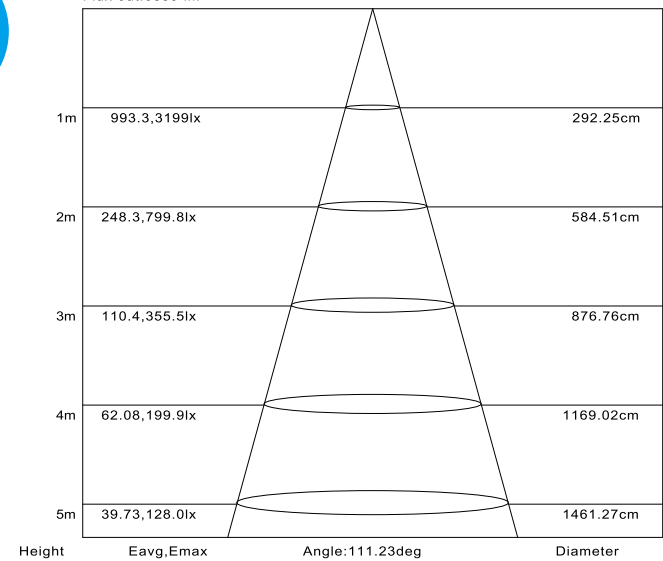

# Installation and use

Environmental Conditions	Ambient Temp	Storage Temp	Relative humidity	Atmosphere Pressure	Heat sink Mode	Protection degree
	-30—+45℃	-40—70℃	10—85%	70—106kPa	Natural Heat Conduction	IP65

## (1).Hook Installation

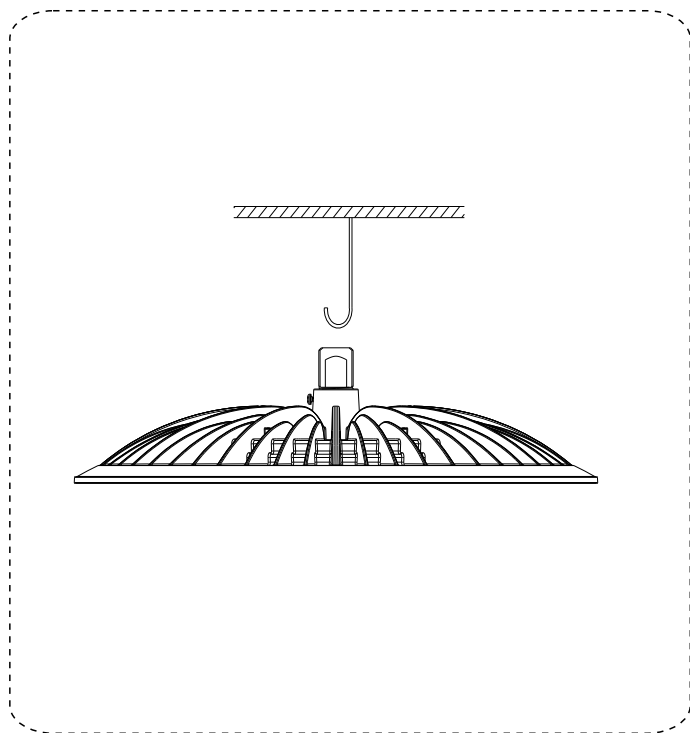

## (2)Pole mounted

The Pole mounted schematic

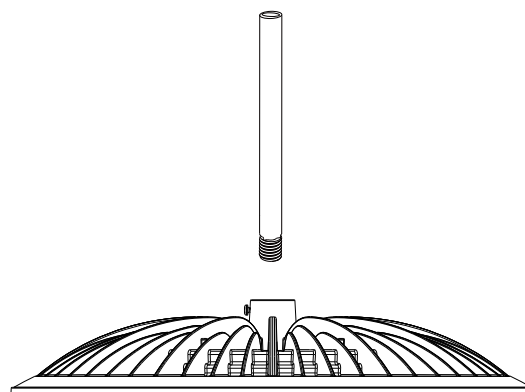

## (3)Lifting Installation

Lifting schematic

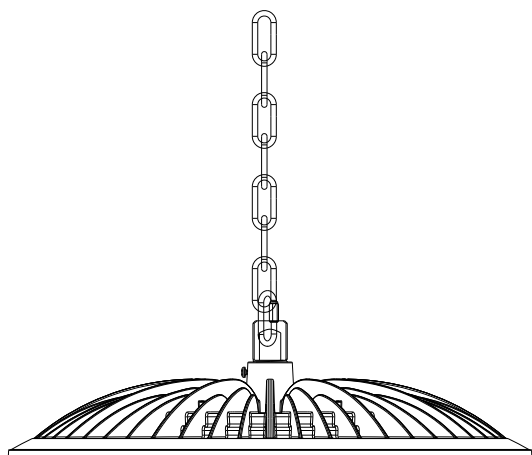

# Logistical Data

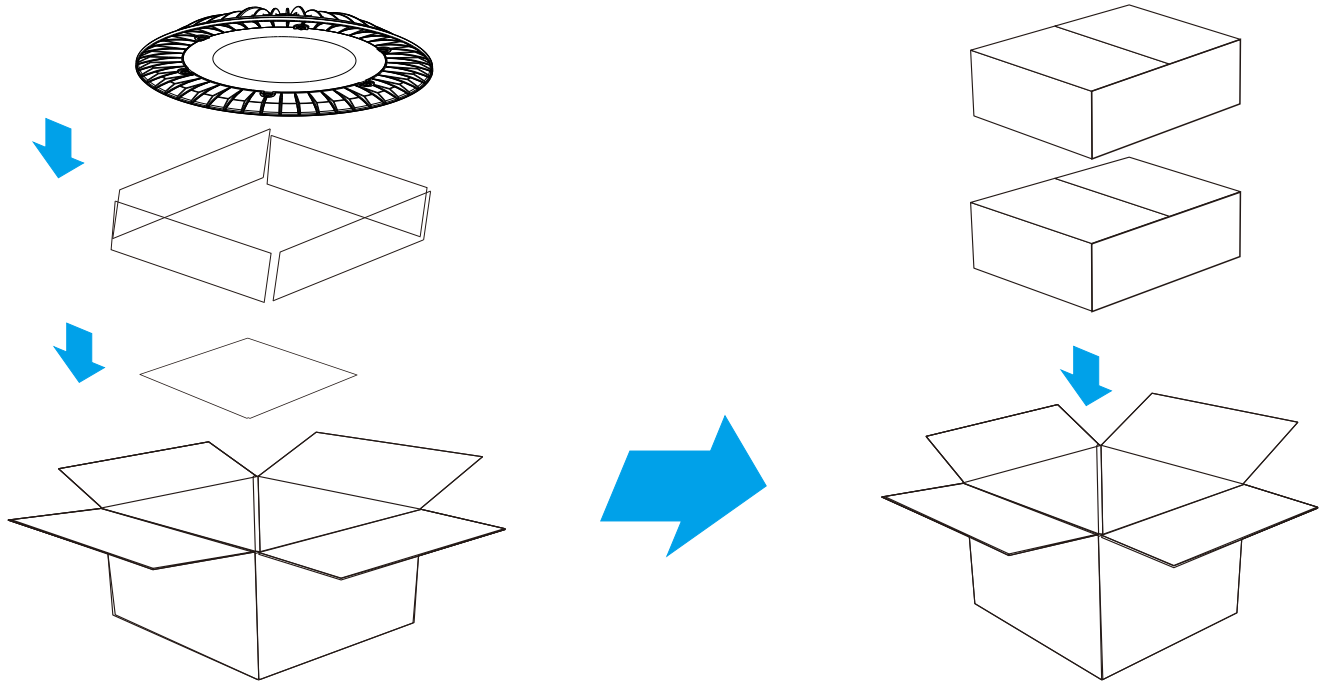

Model#	N.W	Inner box size	Quantity	G.W	Carton Size	G.W	PCS/CTN
HG063	1.3KG	335*335*80mm	1PCS	1.85KG	360*360*400mm	8.5KG	4PCS
HG103	1.3KG	335*335*80mm	1PCS	1.85KG	360*360*400mm	8.5KG	4PCS
HG153	2.0KG	385*385*90mm	1PCS	2.6KG	410*410*440mm	12.0KG	4PCS
HG203	2.0KG	385*385*90mm	1PCS	2.6KG	410*410*440mm	12.0KG	4PCS